

ALIGN

AIR POWER DRAWBAR OPERATION MANUAL

PD-150/PD-200

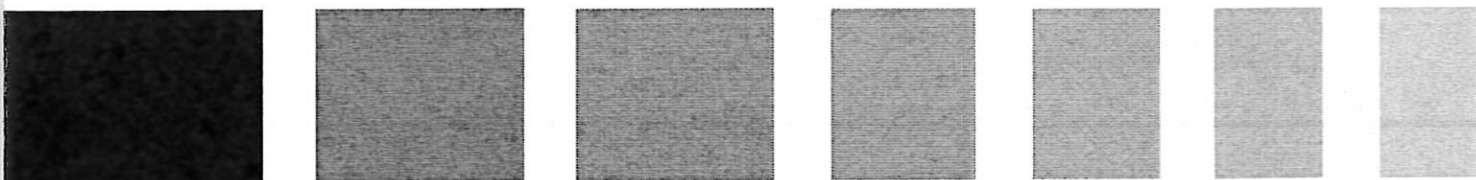
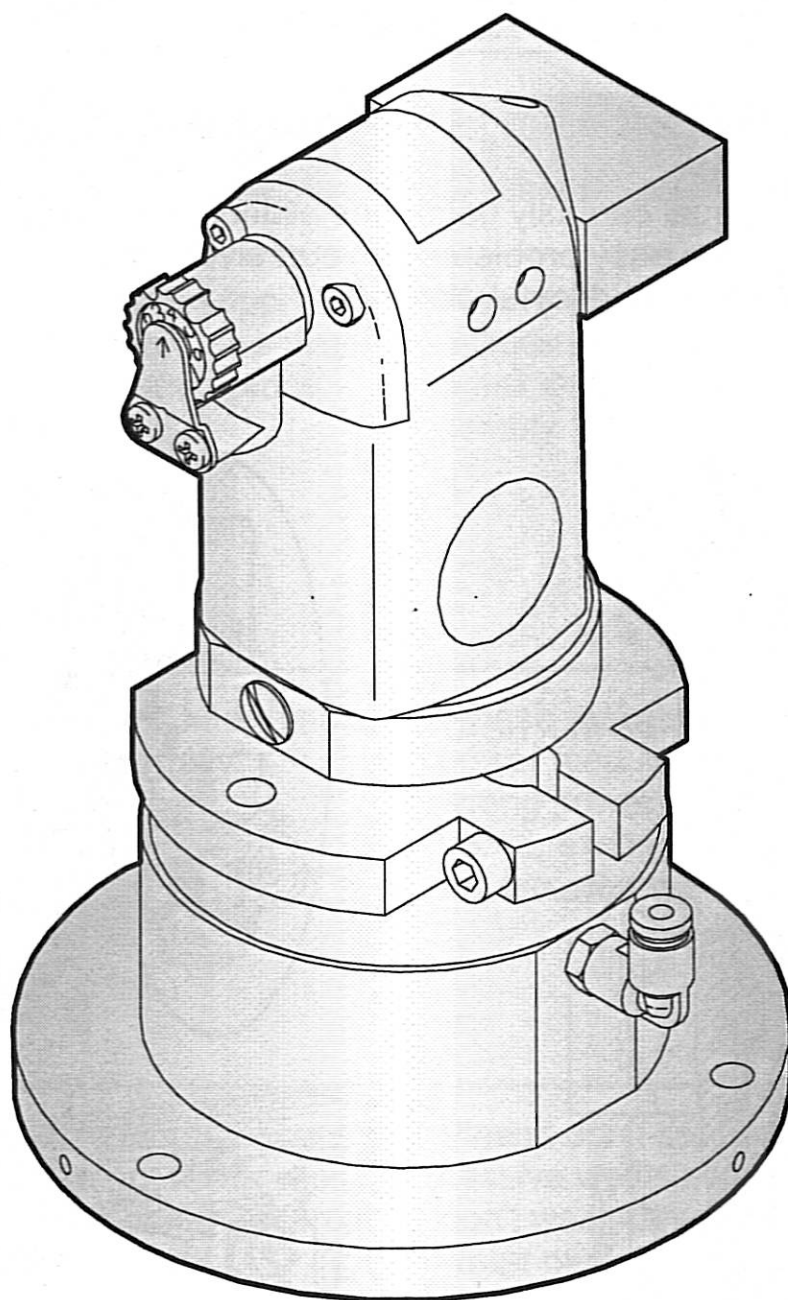

INDEX

PAGE	INDEX
2	SPECIFICATION
2	WARNING
3	HOW TO INSTALL THE POWER DRAWBAR & ACCESSORY
4	SCHEMATIC DIAGRAM OF PARTS
5	SCHEMATIC DIAGRAM OF ACCESSORY
6	PARTS LIST
7,8	PARTS LIST FOR ACCESSORY

CONGRATULATIONS ON YOUR NEW PURCHASE OF OUR AIR POWER DRAWBAR

Please read this manual carefully before installation and using it. It will also help you to solve some easy problems by yourselves. Hope our product will bring you more effective and joyful working.

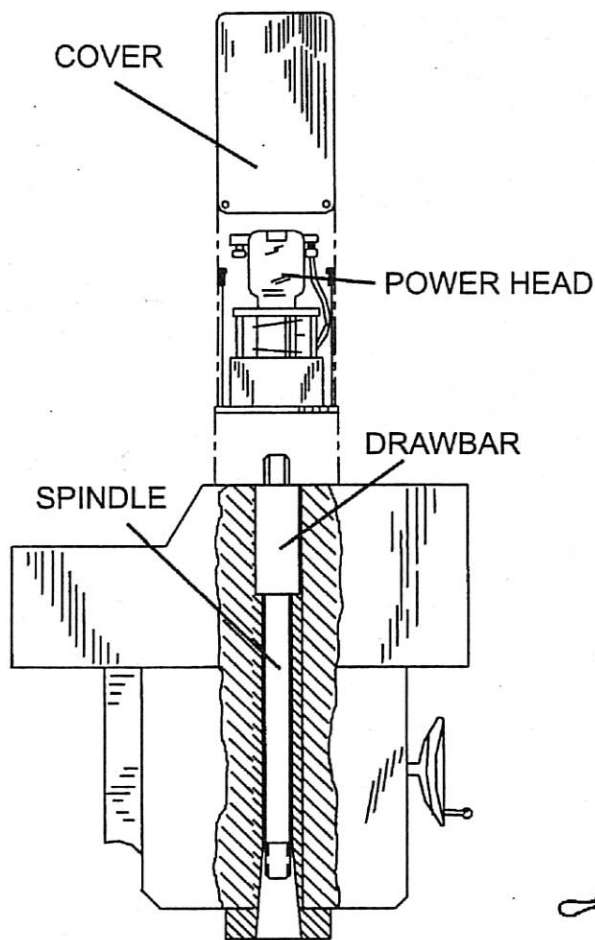

MILLING MACHINE HEAD

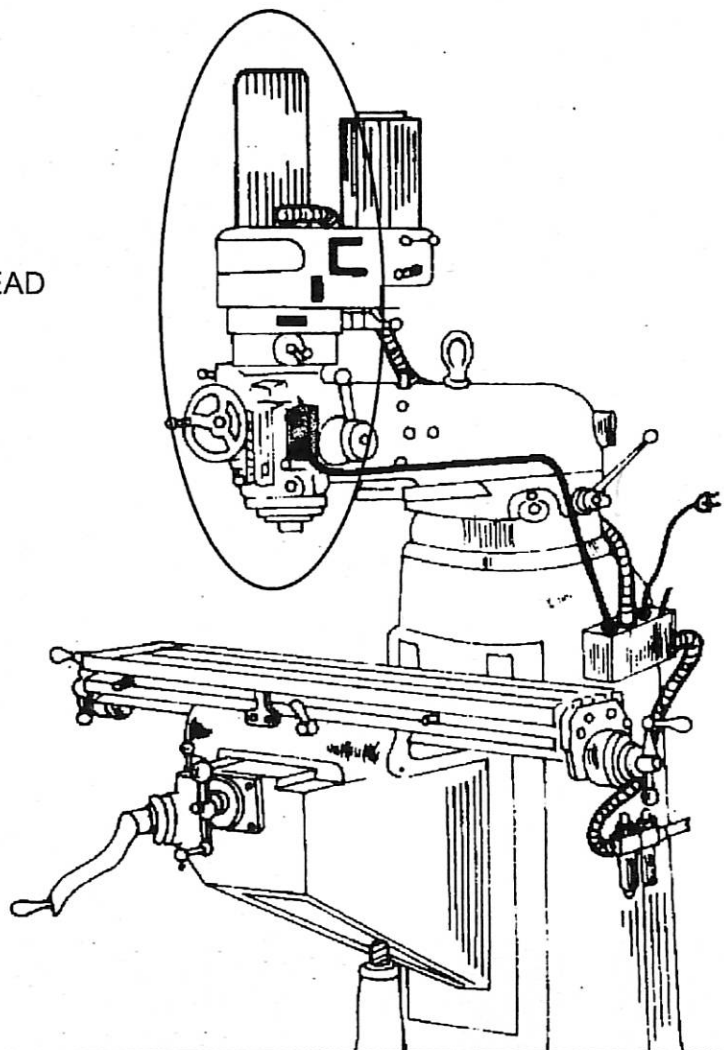

SPECIFICATION

MODEL	PD-150	PD-200
R.P.M	3000	3000
TORQUE	135 ft-lb	135 ft-lb
AIR PRESSURE	90psi/6.3kg-cm	90psi/6.3kg-cm
VOLTAGE	(110V.220V.AC24V) 50/60Hz	(110V.220V.AC24V) 50/60Hz

WARNING

Please make sure if power supply be turned off before assembly, and avoid from accident caused during procedure of assembly.

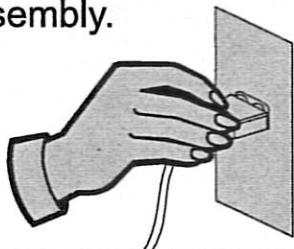

Please don't disassemble for fixing or refitment and free from accident or break down caused by unhealth assembly.



Please take apart the drill and remove worked item before assembly.

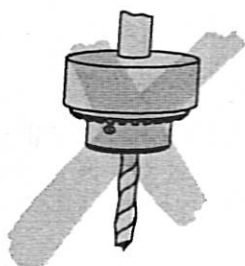

Please make sure input voltage for power feed as A.C.110 V and avoid wrong power then burn down circuit board, except A.C.110 V, please adopt the transformer.



Please adjust suitable length of cord and watch out the wiring, never pressure power cord by clog then ambroin broken cause short or spark.

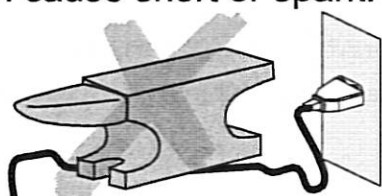

Please don't set the power feed in excessive wettish working zone and don't wash down the power feed by water or water shipped then cause short or spark.



HOW TO INSTALL THE POWER DRAWBAR & ACCESSORY

AIR IMPACT WRENCH

There is a trottle button (position A) installed on the power head. The air pressure could be adjusted from 1 to 8 graduation according to user's need.

There 3 hoses inside air pipe (position B) and have been marked separately 1,2,3 on each of them. Please insert them into rapid joint which has the same number.

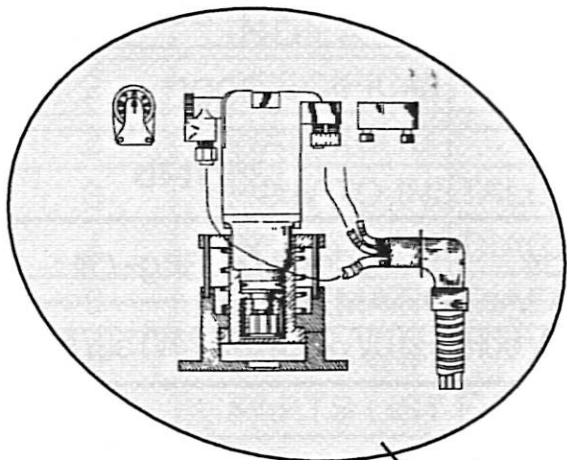

CONTROL BOX OF SOLENOID

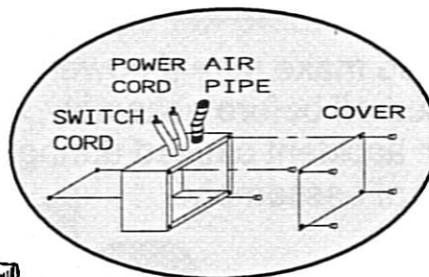

HAND CONTROLLED SWITCH

1. Push tight switch (ON) until tool is securely tightened.
2. Push loose switch (OFF) to disengage tool.

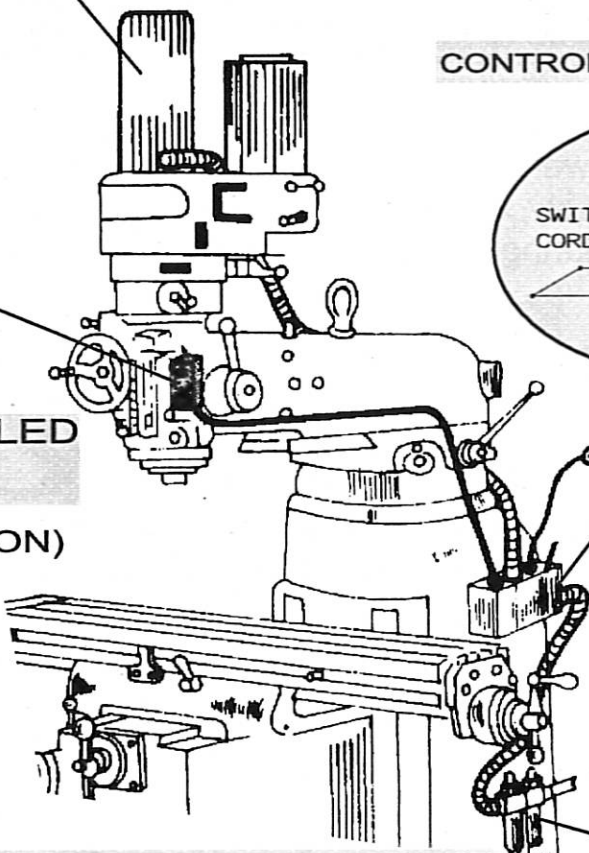

CIRCUIT DIAGRAM FOR SOLENOID VALVE

This air power drawbar is designed with safety device controlled with solenoid. The power drawbar cannot be operated while machine is running. Ensure the main machine power OFF before operation.

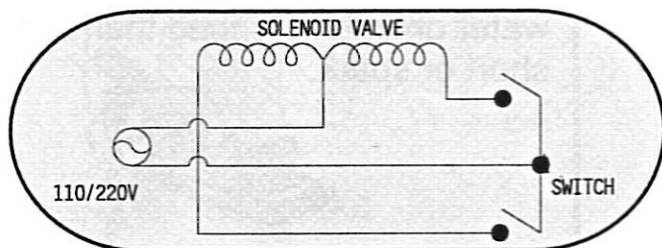

Combination of three-point (Regulator/Filter/Lubricator)

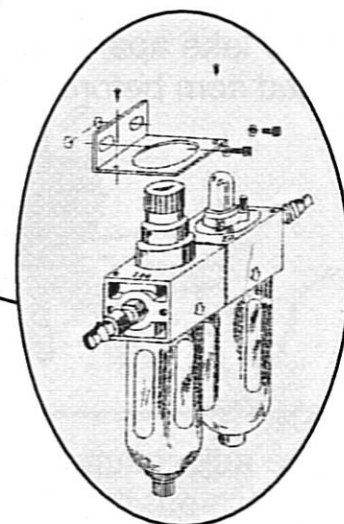

SCHEMATIC DIAGRAM OF PARTS

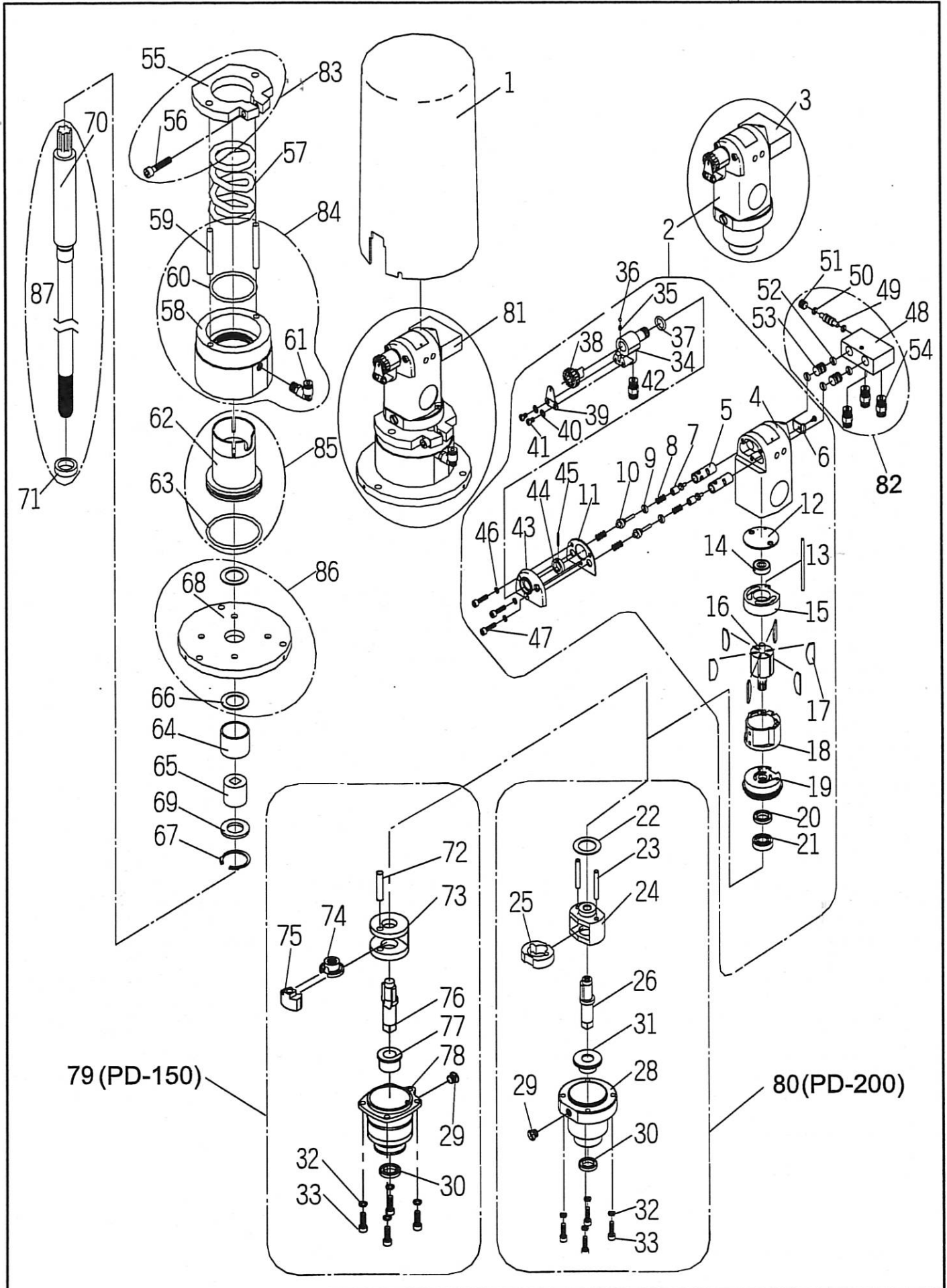

SCHEMATIC DIAGRAM OF ACCESSORY

NO.	PART NAME	PART NO.	SPECIFICATION	REMARK
1	COVER GROUPS	P02901		
2	AIR IMPACT WRENCH	PDM-1V		
3	CONTROL VALVE	P02013		
4	MOTOR HOUSING	P02008	ADC 12	
5	THROTTLE VALVE	P02009	ϕ 21x57.4	
6	PLUNGER STOP PLATE	P02010	SPCE	
7	THROTTLE PLUNGER	P02011	S45C	
8	SPRING	X00052	SWPA ϕ 0.5x13	
9	O-RING	Q00050	SBR	
10	THROTTLE VALVE	P02012	S45C	
11	HOUSING COVER GASKET	Q10001	T1.6	
12	MOTOR GASKET	Q10002	ϕ 39.2xT1.6	
13	MOTOR PIN	U42055	S45C ϕ 2x55	
14	BEARING	B00001	626Z	
15	REAR END PLATE	P02016	ADC 12	
16	ROTOR	P02017	S45C	
17	ROTOR BLADE	P02018		
18	CYLINDER	P02019	S45C	
19	FRONT EBT PLATE	P02020	ADC12	
20	OIL SEAL	Q20001	ϕ 6x ϕ 10x ϕ 16	
21	BEARING	B00002	628z	
22	HAMMER CAGE GASKET	P02078	ϕ 3.5x ϕ 37.7x ϕ 44.7	
23	HAMMER PIN	P02076	ϕ 3.5x ϕ 39.7x ϕ 46.7	
24	HAMMER CAGE	P02075	ϕ 10x ϕ 34xT0.3	
25	DOG	P02077	Fc15	
26	ANVIL	P02074	SNCM 220	
28	HAMMER CASE	P02072	Fc15	
29	OIL PLUG	T98012	M8x12	
30	OIL SEAL	Q20002	ϕ 12.5x ϕ 20.5xT3.6	
31	RUBBER NOSE GUARD	P02073	ϕ 12.6x15	

PARTS LIST

NO.	PART NAME	PART NO.	SPECIFICATION	REMARK
32	WASHER	W20050	φ 5	
33	SCREW	T60001	M6x25	
34	AIR INLET BLOCK	P02002	ZDC1	
35	SPRING	X00051	SWPA	
36	REGULATOR BALL	P02003	φ 2	
37	O-RING	Q00070	P7	
38	REGULATOR	P02004	ZDC1	
39	REGULATOR PLATE	P02005	SPCC	
40	WASHER	W40030	SPCE	
41	SCREW	T14016	M4x16	
42	RAPID JOINT	A10001	φ 8	
43	HOUSING COVER	P02006	ADC12	
44	FIXING RING	P02007	φ 6xT16L	
45	RETAINER PIN		φ 1.5x16L	
46	WASHER	W20040	φ 4	
47	SCREW	T54016	M4x16	
48	CONTROL VALVE ASSY	P02013	A2024P	
49	AIR INLET VALVE-A	P02014	S45C	
50	O-RING	Q00050	P5	
51	SCREW	T71010	M10x10	
52	AIR INLET VALVE-B	P02015	S45C	
53	O-RING	Q00070	P7	
54	PARID JOINT	A10002	φ 4	
55	SET RING	P02028		
56	SCREW	T56030	M5x16	
57	SPRING	X00053	φ 0.5x13	
58	AIR CYLINDER HOLDER	P02030		
59	GUIDE BAR	U46055		
60	O-RING	Q00480		
61	RAPID JOINT	A20001	φ 4	
62	PISTON	P02031		
63	O-RING	Q00570	φ 5.7x φ 57.6x φ 69	

PARTS LIST

NO.	PART NAME	PART NO.	SPECIFICATION	REMARK
64	PLASTIC BUSHING	P02032	Pa6	
65	CLUTCH	P02033		
66	WASHER	W12030	ϕ 20x ϕ 30xT1	
67	CRESCENT RING	F00032	IRTW-32	
68	BOTTOM COVER	P02034		
69	INNER RING	P02035	ϕ 32x ϕ 18xT13	
70	DRAW BAR HEAD	P02036		
70	DRAWBAR	P02037		
71	DRAWBAR RING	P02038		
72	HAMMER CAGE PIN	U46032	ϕ 5.9x32L	
73	HAMMER CAGE	P02021		
74	HAMMER CAM	P02022		PD-150
75	DOG	P02023		PD-150
76	ANVIL	P02025		PD-150
77	RUBBER NOSE GUARD	P02027		PD-150
78	HAMMER CASE	P02026		PD-150
79	HAMMER CASE GROUPS	P02907		PD-150
80	HAMMER CASE GROUPS	P02912		PD-200
81	HOST GROUPS	PDM1-2V		PD-150
	HOST GROUPS	P02913		PD-200
82	CONIROL VALVE GROUPS	PDM2-1V		
83	SET RING GROUPS	PFR3-33		
84	AIR CYLINDER GROUPS	PDM567		
85	PISTON GROUPS	PDM7-3		
86	BOTTOM COVER GROUPS	PDM8-9		
87	BRAWBAR GROUPS	PDM1415A		

PARTS LIST

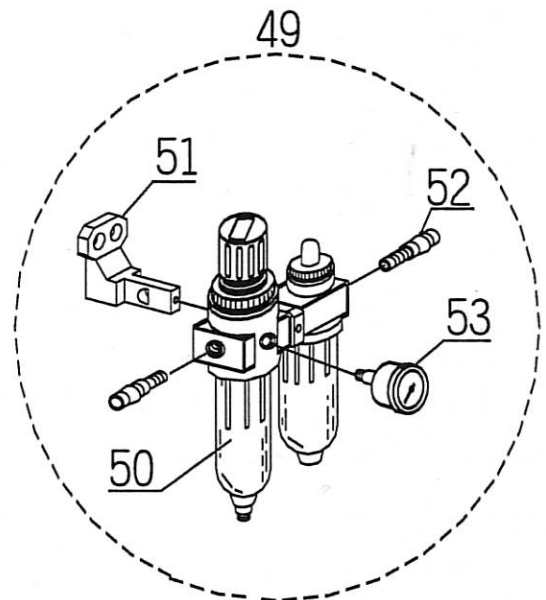
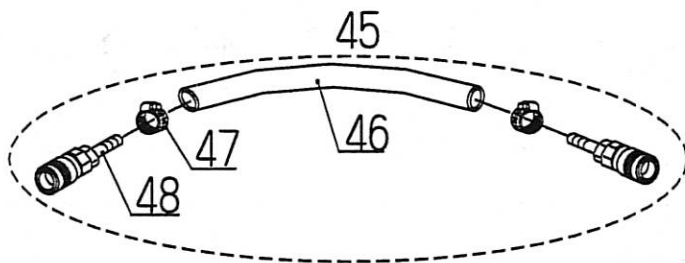
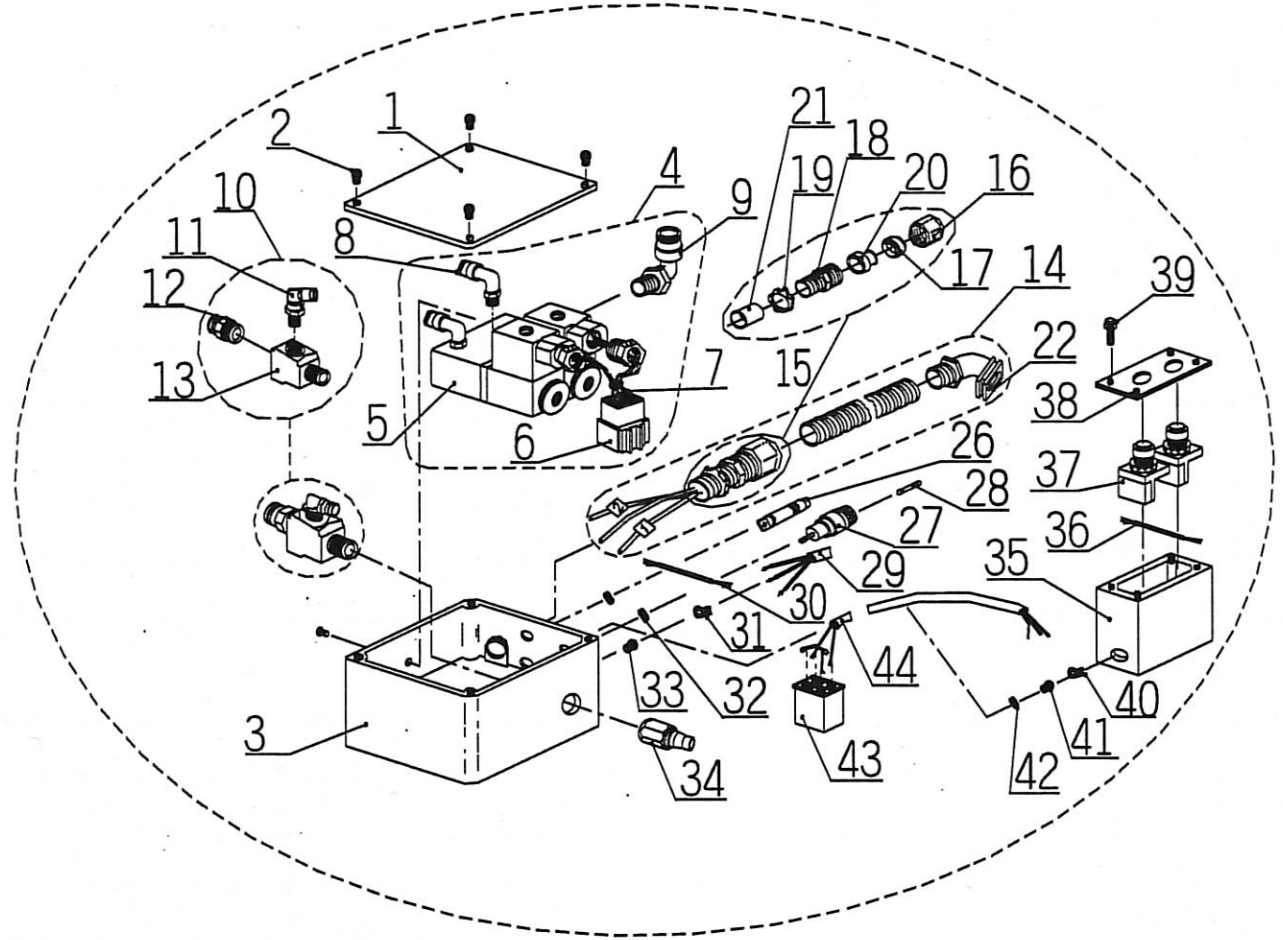

PARTS LIST FOR ACCESSORY

NO.	PART NAME	PART NO.	SPECIFICATION	REMARK
1	CONTROL BOX COVER	P02039		
2	SCREW	T14006	M4X 6	
3	CONTROL BOX HOUSING	P02040		
4	SOLENOID VALVE SET	PDC6		
5	SOLENOID VALVE	PDC3-1		
6	CIRCUIT CONNECTOR	E60004		
7	WIRE	E11102	18AWG	
8	RAPIR JOINT	A20001	SPL-4-01	
9	RAPIR JOINT	A20002	SPL-06-01	
10	T-WAY WITH RAPID JOINT	PDC9-11		
11	RAPIR JOINT	A20003	SPL-6-02	
12	RAPIR JOINT	A10003	SPL-8-02	
13	T-WAY JOINT	P02051		
14	AIR PIPE ASSY	PDC1415		
	JOINT	E60006		
	AIR PIPE	A00001		
15	JOINT ASSY	P02908	3/8" X2.5M	
16	NUT	P02043		
17	CAP	P02041		
18	JOINT	P02042		
19	NUT	P02044		
20	NUT	P02045		
21	NUT	P02046		
24	PU TUBE	P02048	φ 4X φ 2.5X φ 2.5M	
	PU TUBE	P02049	φ 5X φ 8X φ 2.5M	
	PU TUBE	P02050	φ 6X φ 8X φ 2.5M	
26	LIGHT	P02056		
27	FUSE HODER	E50901		
28	FUSE	E50051	4A	
29	POWER CORD	E23012	3CX0.75X2M	
30	WIRE	E10106	18AWG	
31	WIRE HODER	A0100-08A	UC-1	
32	WIRE CLAMP	P02057		
33	SCREW	T14006	M4X6	
34	RAPID JOINT	A10004	PF 20	

ALIGN

G00181B

ALIGN CORPORATION LIMITED
<http://www.align.com.tw>